

013R9305

013R9305

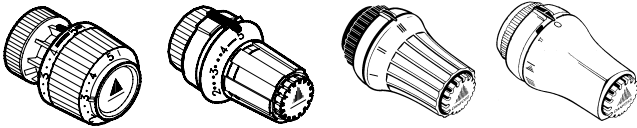

Montage
Mounting

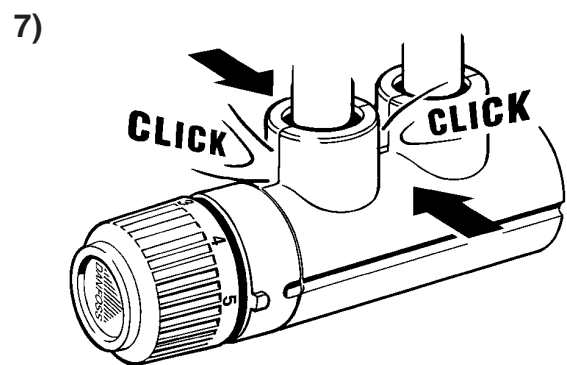
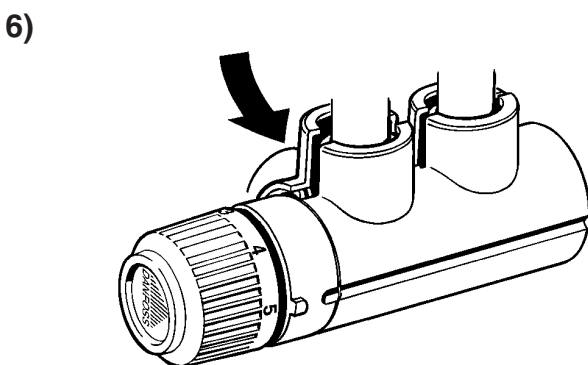
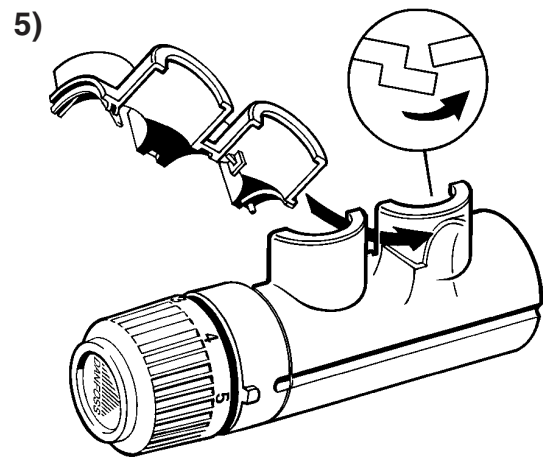
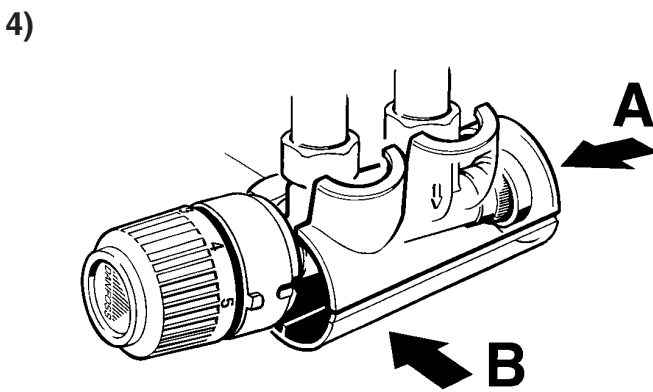
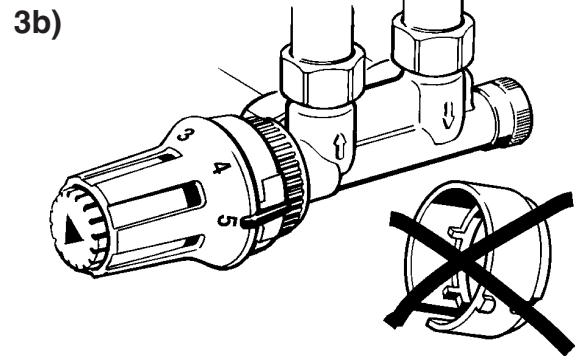
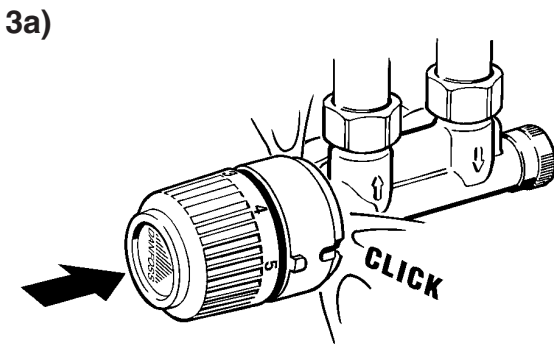
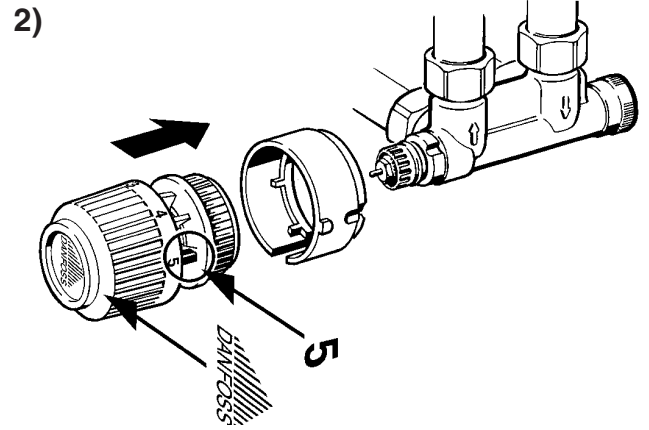
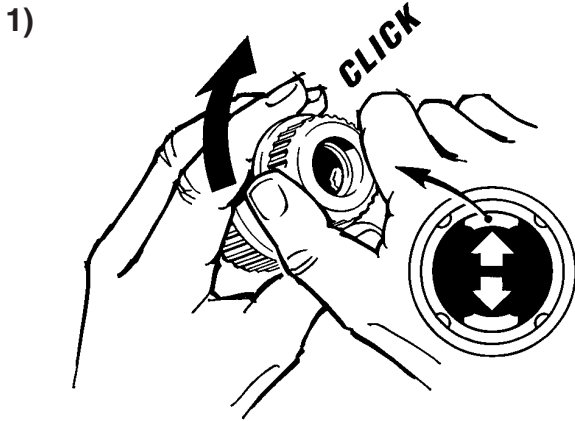

Demontage - Removal

1)

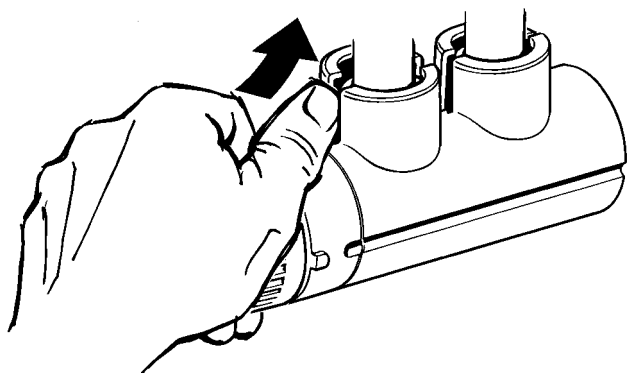

2)

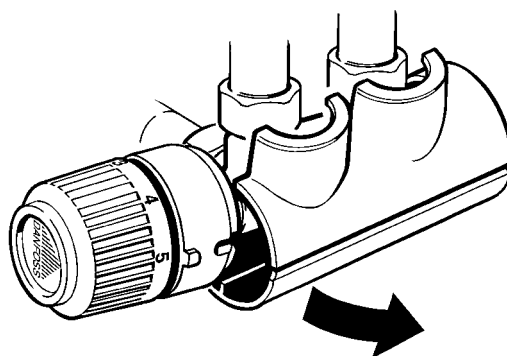

3)

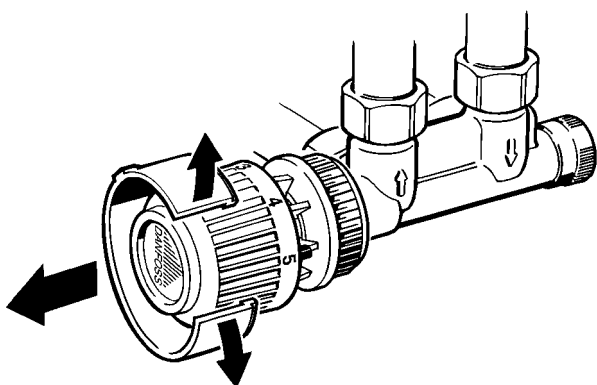

4)

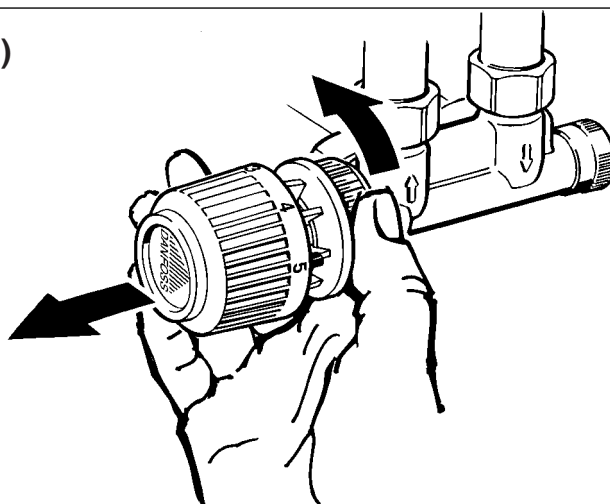

Anleitung zum Nasslackieren der Abdeckkappe:

Material:	Ceycolac S704S weiß (ABS)
Vorbehandlung:	Vorbehandlung ist nicht notwendig
Temperatur:	Max. 80° C
Lack:	Mit ABS kompatibel
Aufhängung:	Innen im Deckel befestigen
Farbtöne:	Keine Einschränkung
Helle Farbe:	Schichtdicke nicht kritisch
Dunkle Farbe:	Evtl. zusätzliche Schicht
Schichtdicken:	15 - 20 µ/Schicht
Weitere Informationen:	GE Plastics: Painting Guide

GE Plastics
European Headquarters
General Electric Plastics B.V.
1 Plasticslaan, PO Box 117
NL-4600 AC Bergen op Zoom
The Netherlands
Tel. (31)(164) 29 29 11
Fax (31)(164) 29 49 40

General Electric Plastics GmbH
Eisenstraße 5
D-65428 Rüsselsheim
Deutschland
Tel. (49)(6142)6010
Fax (49)(6142)65746

Fehlersuche:

Mangelhaftes Anhaften:	Farbsystem ist nicht mit ABS kompatibel
Orangenhaut:	Folge der verwendeten Lackierungstechnologie, d.h. Spray und Viskosität

Guidelines for wet lacquering of cover:

Material:	White Ceycolac S704S (ABS).
Pre-treatment:	Pre-treatment is not necessary.
Temperature:	Max. 80° C.
Lacquer:	Compatible with ABS.
Suspension:	To be fastened to inside of cover.
Colour shades:	All shades.
Light shade:	Layer thickness not critical.
Dark shade:	Possibly extra layer.
Layer thicknesses:	15-20 µ/ layer.
Further information:	GE Plastics: Painting Guide

GE Plastics
European Headquarters
General Electric Plastics B.V.
1 Plasticslaan, PO Box 117
NL-4600 AC Bergen op Zoom
The Netherlands
Tel. (31)(164) 29 29 11
Fax (31)(164) 29 49 40

General Electric Plastics GmbH
Eisenstraße 5
D-65428 Rüsselsheim
Germany
Tel. (49)(6142)6010
Fax (49)(6142)65746

Fault-finding:

Inadequate adhesion:	Paint system not compatible with ABS.
“Orange peel”	An effect of the application technology as applied, i.e. spray and viscosity.